

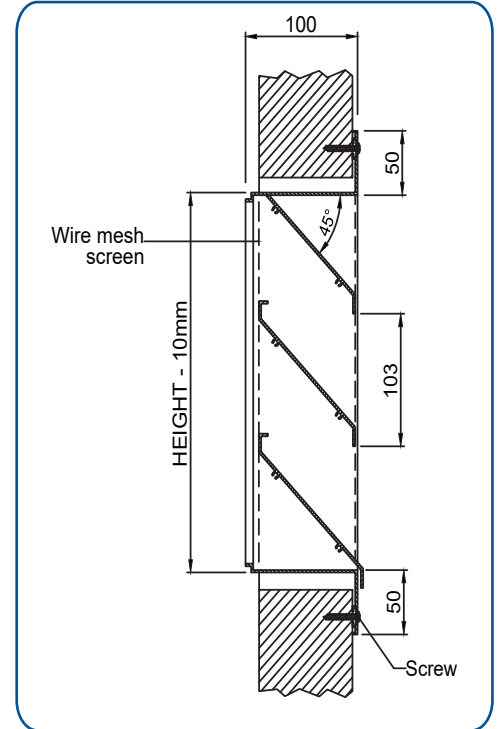

LOUVERS

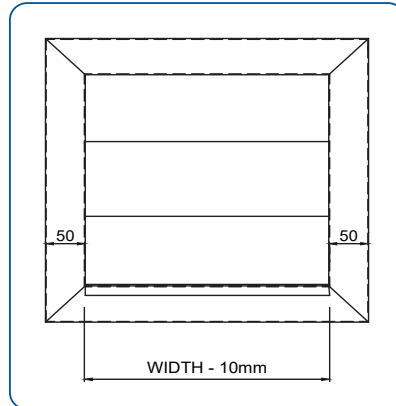

- >> The exhaust air louver is composed of a set of blades made of 2MM aluminum extruded profile/ GI sheet arranged in 45 degree in horizontal rows and inclined downward to protect against rain water.
- >> The exhaust air louver is used in cooling, heating and air ventilation applications for intake & discharge.
- >> Frame depth 100MM, spacing 87MM & blade angle 45.
- >> The wall mounted exhaust air louver EAL-4 is a weather proof external cover for air inlet and discharge openings.

FREE AREA CHART (SQUARE FEET)

		Width (inches)												
		12	18	24	30	36	42	48	54	60	66	72	78	
Height (inches)	Out to Out	Neck Size	8.06	14.06	20.06	26.06	32.06	38.06	44.06	50.06	56.06	62.06	68.06	74.06
	12	8.06	0.18	0.32	0.46	0.60	0.75	0.89	1.03	1.17	1.32	1.46	1.60	1.75
	18	14.06	0.35	0.64	0.92	1.21	1.50	1.78	2.07	2.35	2.64	2.92	3.21	3.50
	24	20.06	0.71	1.28	1.85	2.42	2.99	3.56	4.13	4.70	5.27	5.85	6.42	6.99
	30	26.06	0.88	1.6	2.31	3.02	3.74	4.45	5.17	5.88	6.60	7.31	8.02	8.73
	36	32.06	1.23	2.23	3.23	4.22	5.22	6.22	7.21	8.21	9.21	10.20	11.20	12.19
	42	35.06	1.41	2.56	3.70	4.84	5.98	7.12	8.26	9.41	10.55	11.69	12.83	13.97
	48	44.06	1.76	3.17	4.59	6.01	7.43	8.84	10.26	11.68	13.10	14.52	15.93	17.35
	54	50.06	1.94	3.51	5.08	6.65	8.22	9.79	11.36	12.93	14.50	16.07	17.64	19.21
	60	56.06	2.28	4.12	5.96	7.79	9.63	11.47	13.31	15.15	16.99	18.83	20.67	22.51
	66	62.06	2.48	4.47	6.47	8.47	10.47	12.47	14.46	16.46	18.46	20.46	22.46	24.45
	72	68.06	2.8	5.06	7.32	9.58	11.84	14.10	16.36	18.62	20.88	23.14	25.40	27.66
	78	74.06	3.00	4.43	7.86	10.28	12.71	15.14	17.56	19.99	22.42	24.84	27.27	29.69

Ordering Key:

E	A	L	4 A/G	IS	SIZE
EAL4A: EXHAUST AIR LOUVER WITH 4 INCH DEPTH IN ALUMINIUM EAL4G: EXHAUST AIR LOUVER WITH 4 INCH DEPTH IN GI					
-: WITHOUT SCREEN/WIRE MESH					
IS: WITH G.I. INSECT SCREEN SSWM: WITH STAINLESS STEEL WIRE MESH					
SIZE: WIDTH X HEIGHT (NECK SIZE)					
**NOTE: 78 INCH X 78 INCH (OUT TO OUT) IS MAXIMUM SINGLE SECTION SIZE					





Beta Industrial LLC certifies that the EAL4 shown hereon is licensed to bear the AMCA Seal. The ratings shown are based on tests and procedures performed in accordance with AMCA Publication 511 and comply with the requirements of the AMCA Certified Ratings Program.

The AMCA Certified Ratings Seal applies to Air Performance and Water Penetration ratings.

The beginning point of water penetration is 752.1 fpm

Test Information

Tested in accordance with ANSI/AMCA 500-L, Figure 5.5 Test sample size is 1219mm x 1219mm (48 in. x 48 in.) (Out to Out). Air Performance data are based on exhaust performance

PRESSURE DROP DATA

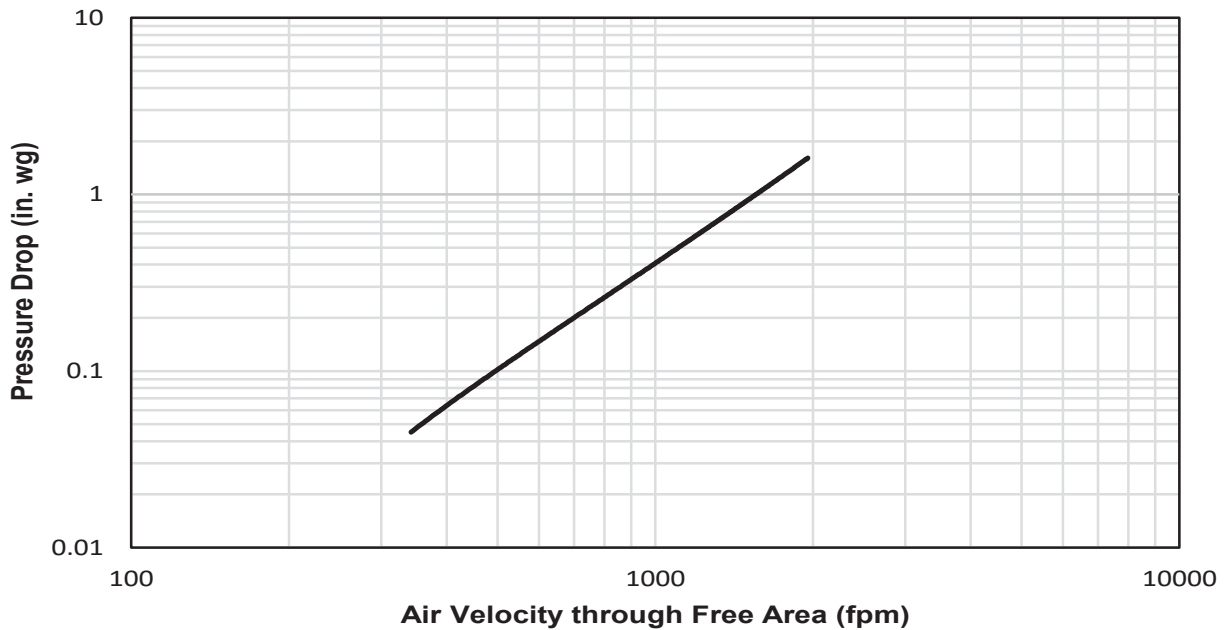

WATER PENETRATION DATA

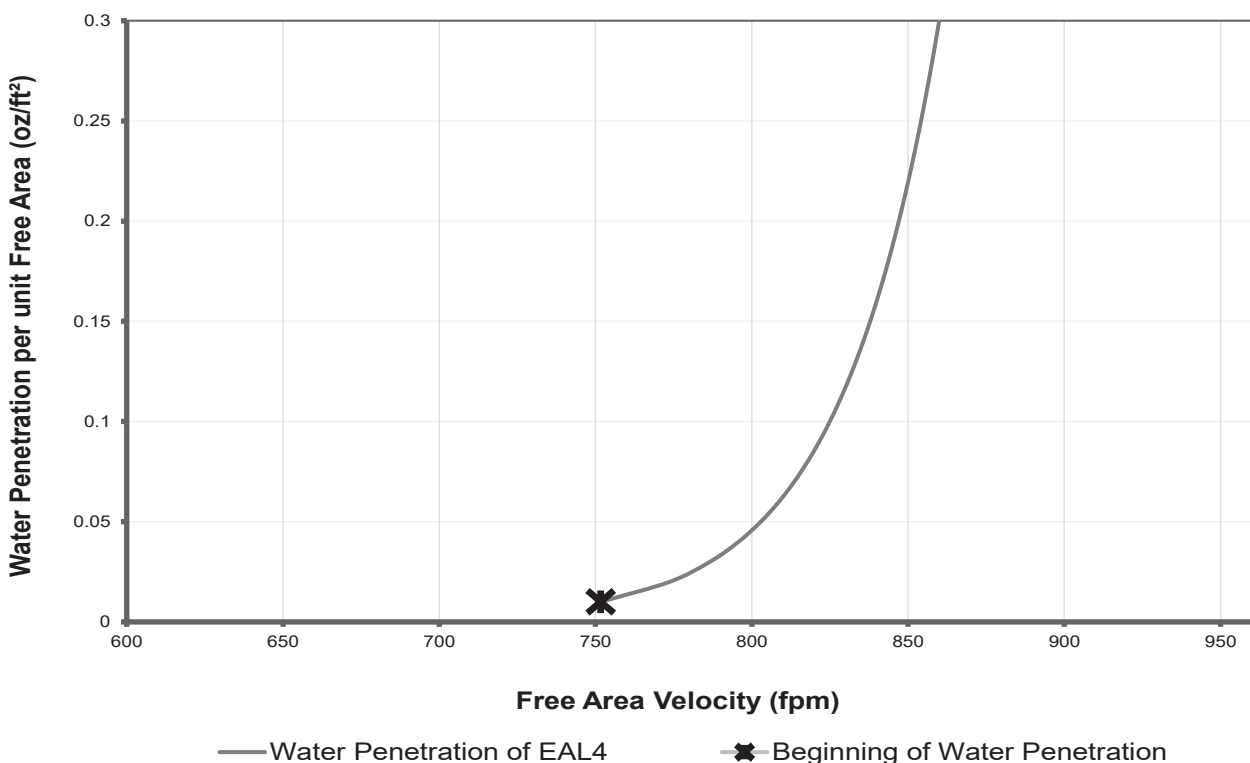

— Water Penetration of EAL4 —X— Beginning of Water Penetration

